

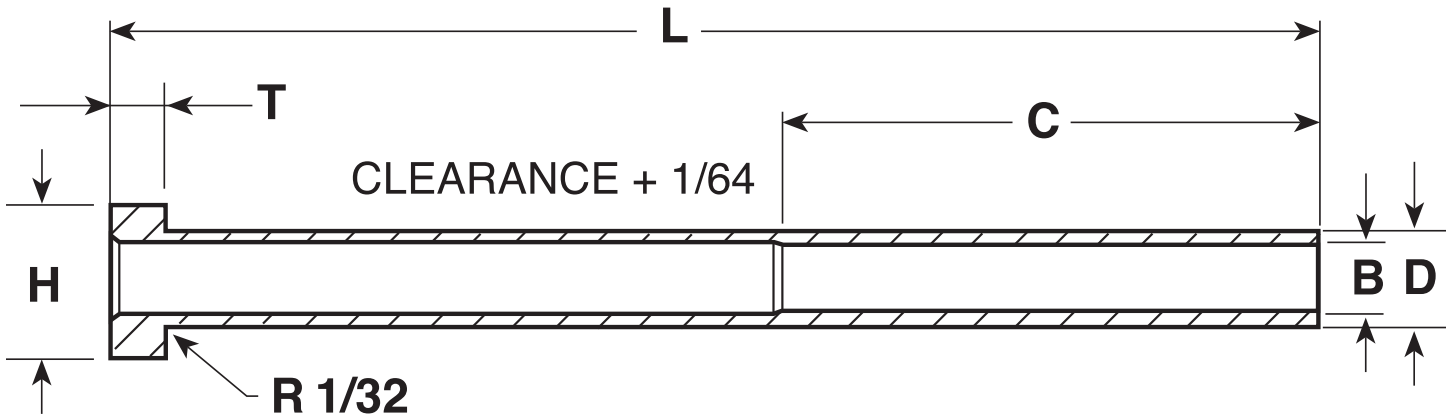

FAXABLE QUOTE FORM PARALLEL EJECTOR SLEEVES (inch)



Size	Tolerance	✓	Special Tolerance	Quantity
D =	-.0003 -.0008	<input type="checkbox"/>	or	_____
B =	+.0003 --.0000	<input type="checkbox"/>	or	_____
H =	+.000 -.010	<input type="checkbox"/>	or	_____
T =	+.000 -.002	<input type="checkbox"/>	or	_____
L =	+.031 -.000	<input type="checkbox"/>	or	_____
C =	+ -	<input type="checkbox"/>	or	_____
				Material
				Hardness/Heat Treatment
				Required by

Company: _____

Address: _____

City: _____ State/Prov.: _____ Zip/Postal Code: _____

Phone: _____ Fax: _____ Email: _____

Contact Name: _____ Reference #: _____

DMS (Windsor)
Fax: 800-845-3807

DMS (Schaumburg)
Fax: 847-885-6075
800-367-4199

DMS (Fountain Valley)
Fax: 714-751-3861
800-953-9561

DMS (Taunton)
Fax: 800-845-3807